

# 1x12 HartVue R8612

**Product**

**Colors\***

Standard color

**Availability**

 Direct print  
Label

**Egg Sizes**

Our R8612 egg cell is constructed for weight classes S, M, L and XL.

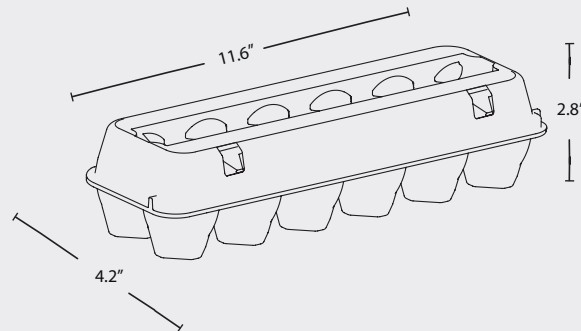
**Product Dimensions\***

	Length	Width (open)	Height (open)	Width (closed)	Height (closed)
<b>Millimeter-Measurements</b>	295	246	53	107	71
<b>Inches-Measurements</b>	11.6	9.7	2.1	4.2	2.8

1x12 HartVue R8612

### Average Dry Weight\*

With direct print:      54 g                  1.9 oz

### Bundle Specs

Cartons: 125	Length	Width	Height	Direct print
<b>Millimeter-Measurements</b>	1016	246	295	<b>Bundle Weight</b> 8.1 kg    17.9 lbs
<b>Inches-Measurements</b>	40	9.7	11.6	

### Machine Settings

**Moba Code: HAI207**

Gripper Set No.: 912

Denester Settings

L	G	J	II	I2
14	14	6	14	36

### Print Parameters

Direct print:

Top: 4-colour

Front and rear: 2-colour

Inlid print:

1-colour black

Barcode



Back of package

Top of package

Top of package

Front of package

Modules for labels and print areas can be downloaded at [www.hartmann-packaging.com](http://www.hartmann-packaging.com)

*\*Colours, weights and dimensions of the products may differ due to the nature of the material, moist variations, production variations, storage and transport conditions.*