

# 1x12 HartVue Jumbo R8712

**Product**

**Colors\***

Standard color

grey

**Availability**

 Direct print  
Label

**Egg Sizes**

Our R8018 egg cell is constructed for weight classes S, M, L and XL.

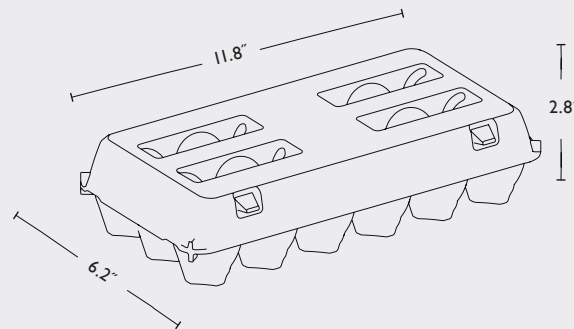
**Product Dimensions\***

	Length	Width (open)	Height (open)	Width (closed)	Height (closed)
<b>Millimeter-Measurements</b>	300	345	48	157	71
<b>Inches-Measurements</b>	11.8	13.6	1.9	6.2	2.8

1x18 HartVue R8018

### Average Dry Weight\*

With direct print: 76 g 2.7 oz

### Bundle Specs

Cartons: 130	Length	Width	Height	Direct print
<b>Millimeter-Measurements</b>	940	345	300	<b>Bundle Weight</b> 9.8 kg 21.5 lbs
<b>Inches-Measurements</b>	37	13.6	11.8	

### Machine Settings

**Moba Code: HAI803**

Gripper Set No.: 912

Denester Settings

L	G	J	II	I2
37	24	8	14	36

### Print Parameters

Direct print:  
Top: 4-colour  
Front and rear: 2-colour

Inlid print:  
I-colour black

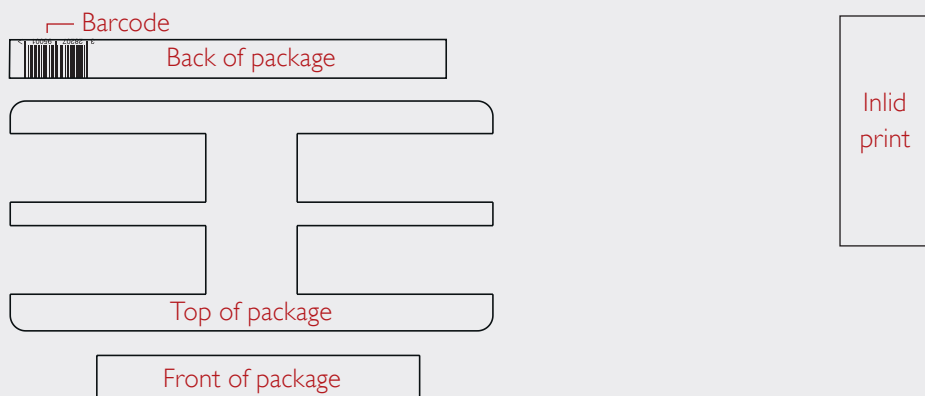

Modules for labels and print areas can be downloaded at [www.hartmann-packaging.com](http://www.hartmann-packaging.com)

\*Colours, weights and dimensions of the products may differ due to the nature of the material, moist variations, production variations, storage and transport conditions.